

M
150-200

2850 1/min

**ДИАГРАММА ГИДРАВЛИЧЕСКИХ
ХАРАКТЕРИСТИК**

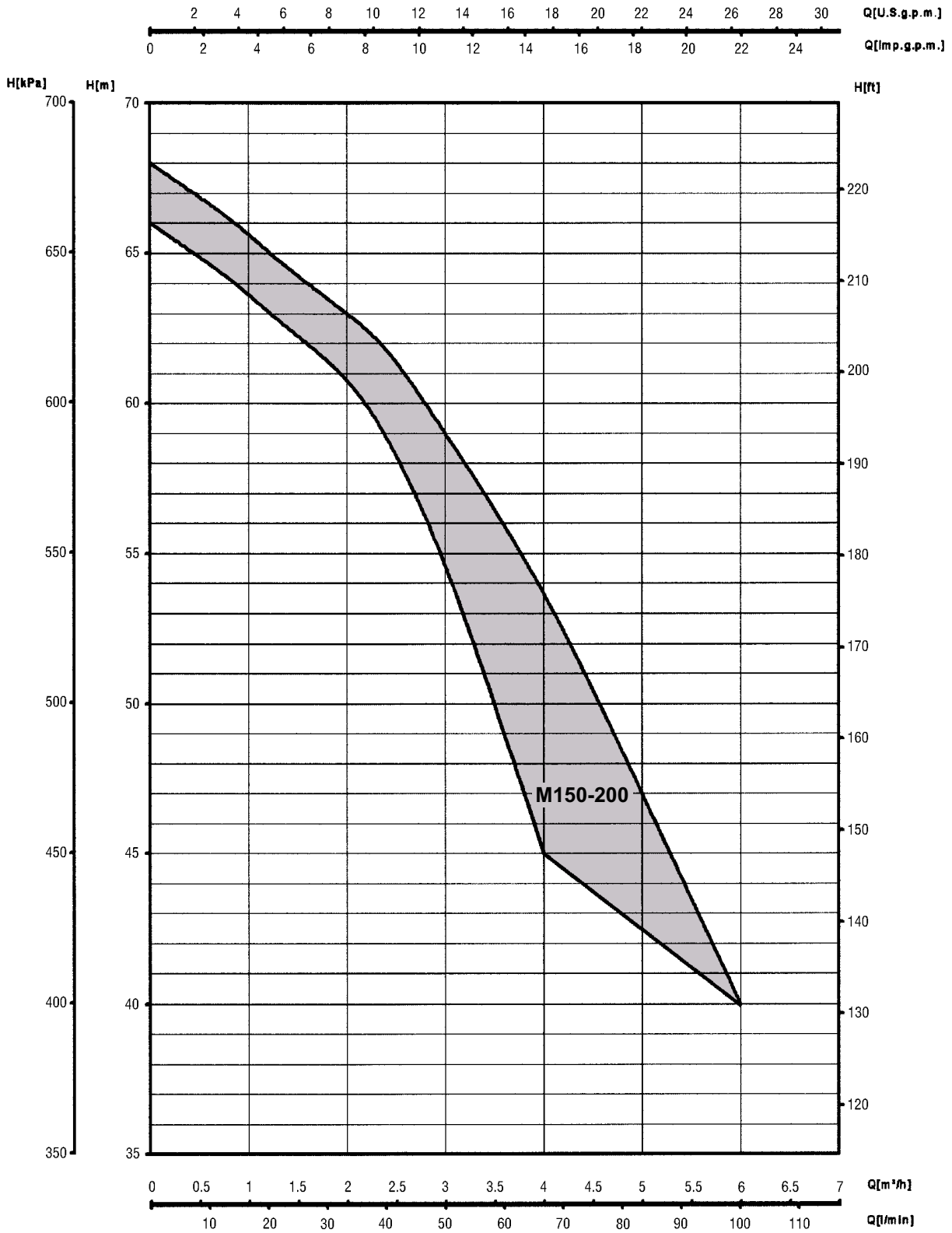

M

150-200

ГИДРАВЛИЧЕСКИЕ ХАРАКТЕРИСТИКИ

Тип	Мощность Max kW	Номинальная мощность		Потребляемый ток A	 μF V	U.S. g.p.m.										
		kW	HP			0	3,9	5,3	8,8	10,5	13,2	17,6	22	26,4		
						m³/h	0	0,9	1,2	2	2,4	3	4	5	6	
M 150	1,83	1,1	1,5	9,5	31,5	450	H	66	64	63	61	59	55	45		
M 200	2,36	1,5	2	11,7	40	450	(m)	68	66	65	63	62	59	54	47	40

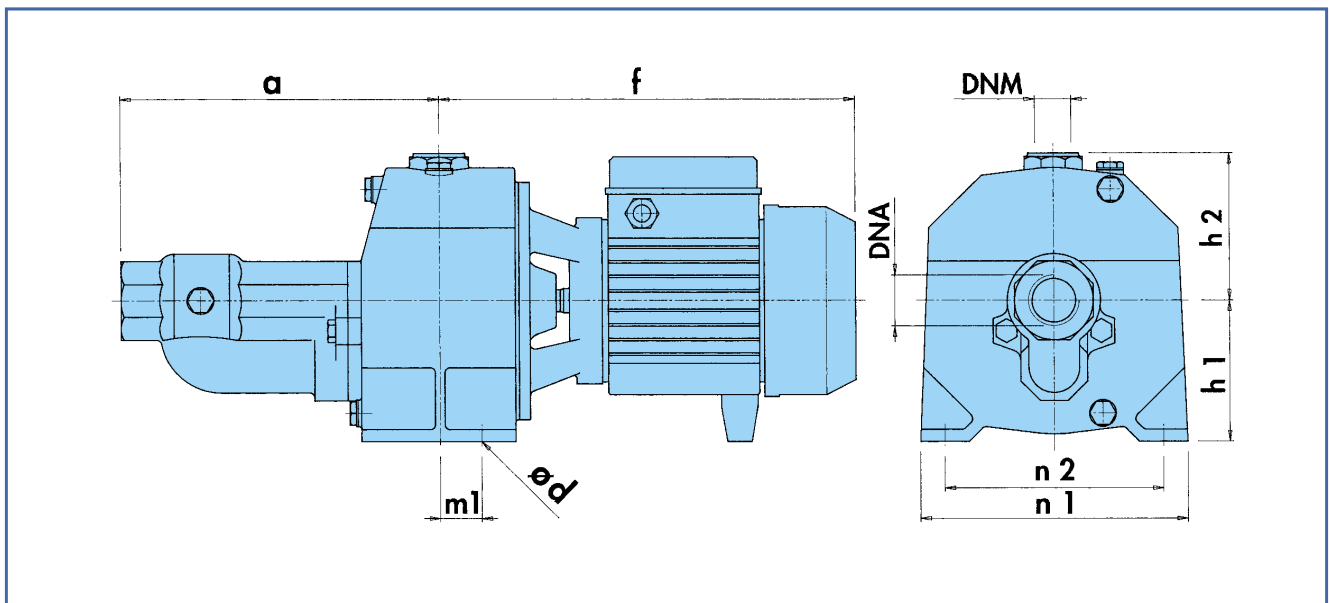

РАЗМЕРЫ И ВЕС

Тип	DNA	DNM	f	a	m1	n1	n2	h1	h2	Ш d	Kg
M 150	G 1" 1/2	G 1"	341	260	34	220	180	114	121	11	29
M 200	G 1" 1/2	G 1"	341	260	34	220	180	114	121	11	31

M150

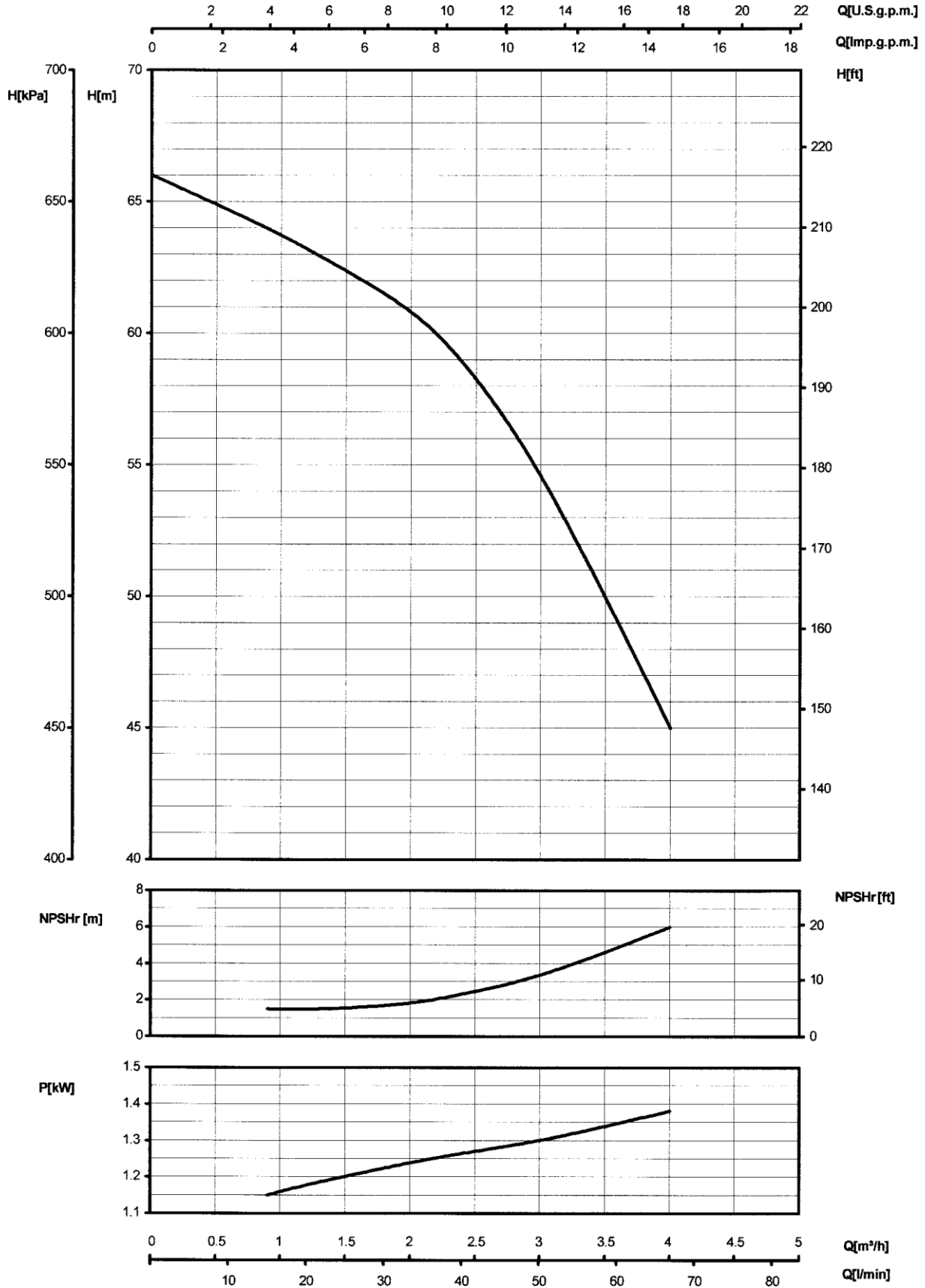

M200

