

KF

0-1-2-3-4

2850 1/min

ДИАГРАММА ГИДРАВЛИЧЕСКИХ ХАРАКТЕРИСТИК

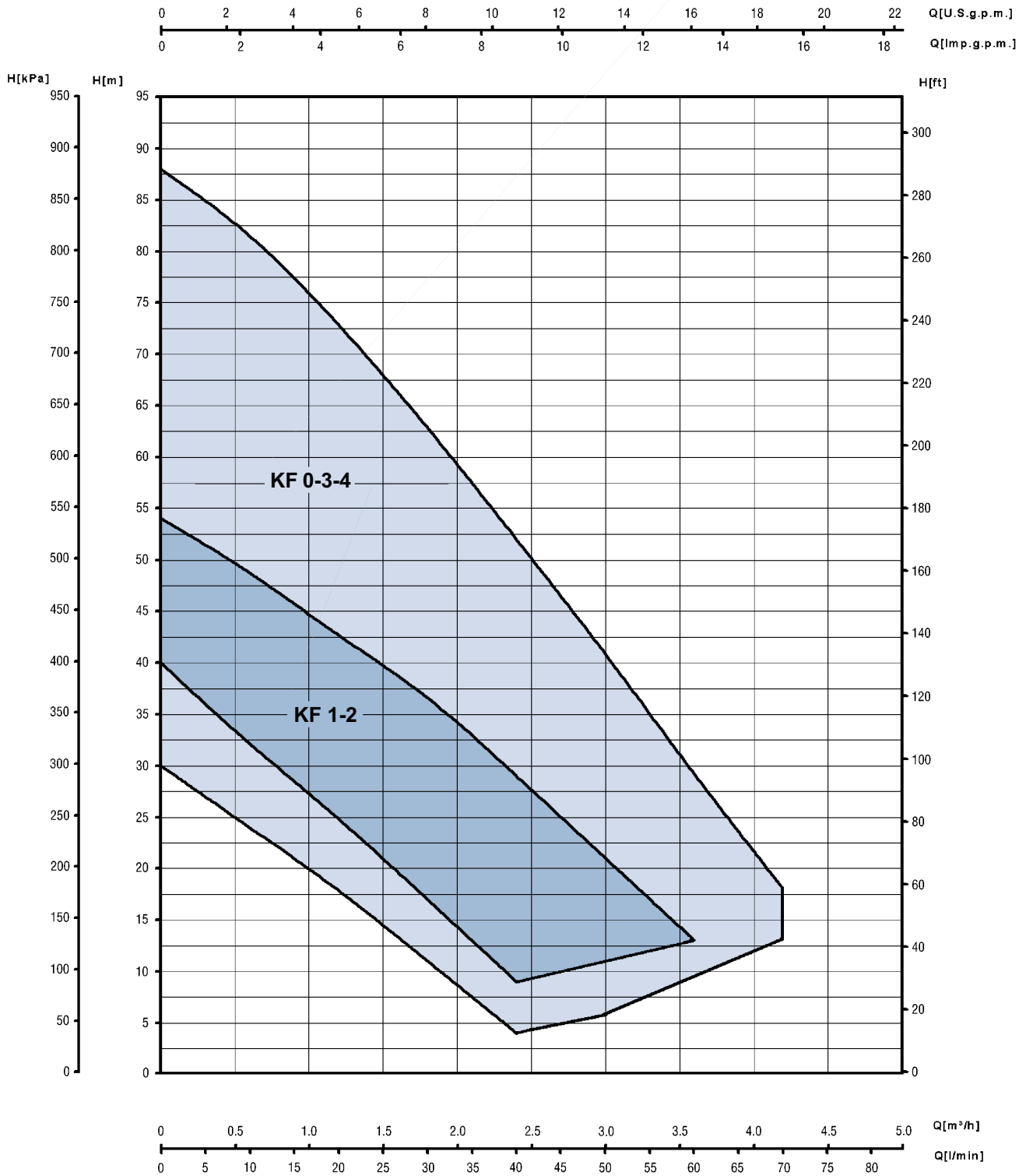

KF

0-1-2-3-4

ГИДРАВЛИЧЕСКИЕ ХАРАКТЕРИСТИКИ

Тип	Мощность Max kW	Номинальная мощность		Потребляемый ток A	—		H (m)							
		kW	HP		μF	V	U.S. g.p.m.	0	2,6	5,3	7,9	10,5	13,2	15,8
							m³/h	0	0,6	1,2	1,8	2,4	3	3,6
							l/min	0	10	20	30	40	50	60
KF 0	0,51	0,37	0,5	2,3	10	450		30	24	18	11	4		
KF 1	0,51	0,37	0,5	2,3	10	450		40	32	25	17	9		
KF 2	1,2	0,55	0,75	5,5	16	450		54	49	42,5	37	29	21	13
KF 3	1,2	0,55	0,75	5,5	16	450		62	50	36	26	17	6	
KF 4	1,43	0,75	1	6,8	20	450		76	63	46	33	22	11	

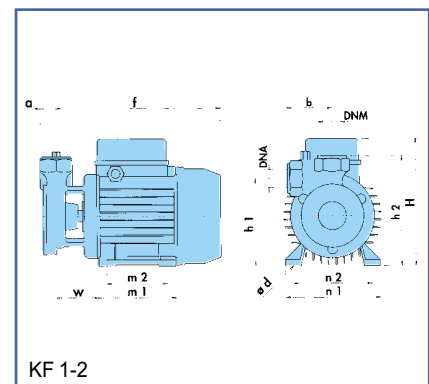
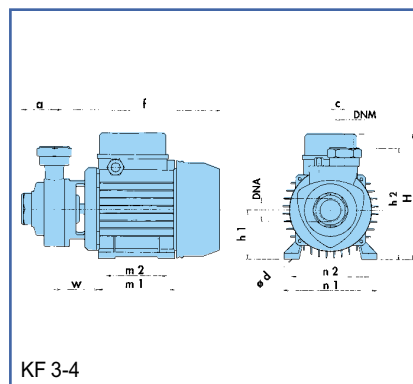
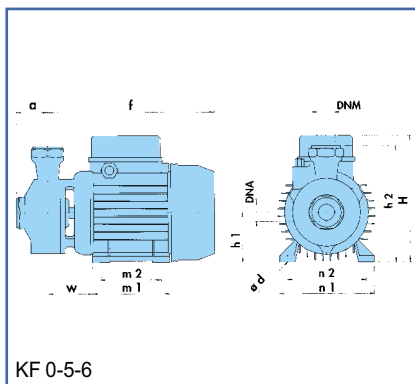

РАЗМЕРЫ И ВЕС

Тип	DNA	DNM	f	a	m1	m2	n1	n2	H	h1	h2	w	Ш d	Kg
KF 0	G 1"	G 1"	215	35	100	80	120	100	166	63	143	60	7	5,2
KF 1	G 1"	G 1"	225	23	100	80	120	100	166	109	143	68	7	5,5
KF 2	G 1"	G 1"	237	23	112	90	135	112	180	124	156	64	7	9,3
KF 3	G 1"	G 1"	240,5	45	112	90	135	112	180	71	161	64,5	7	8,2
KF 4	G 1"	G 1"	240,5	45	112	90	135	112	180	71	161	64,5	7	9,3

KF0

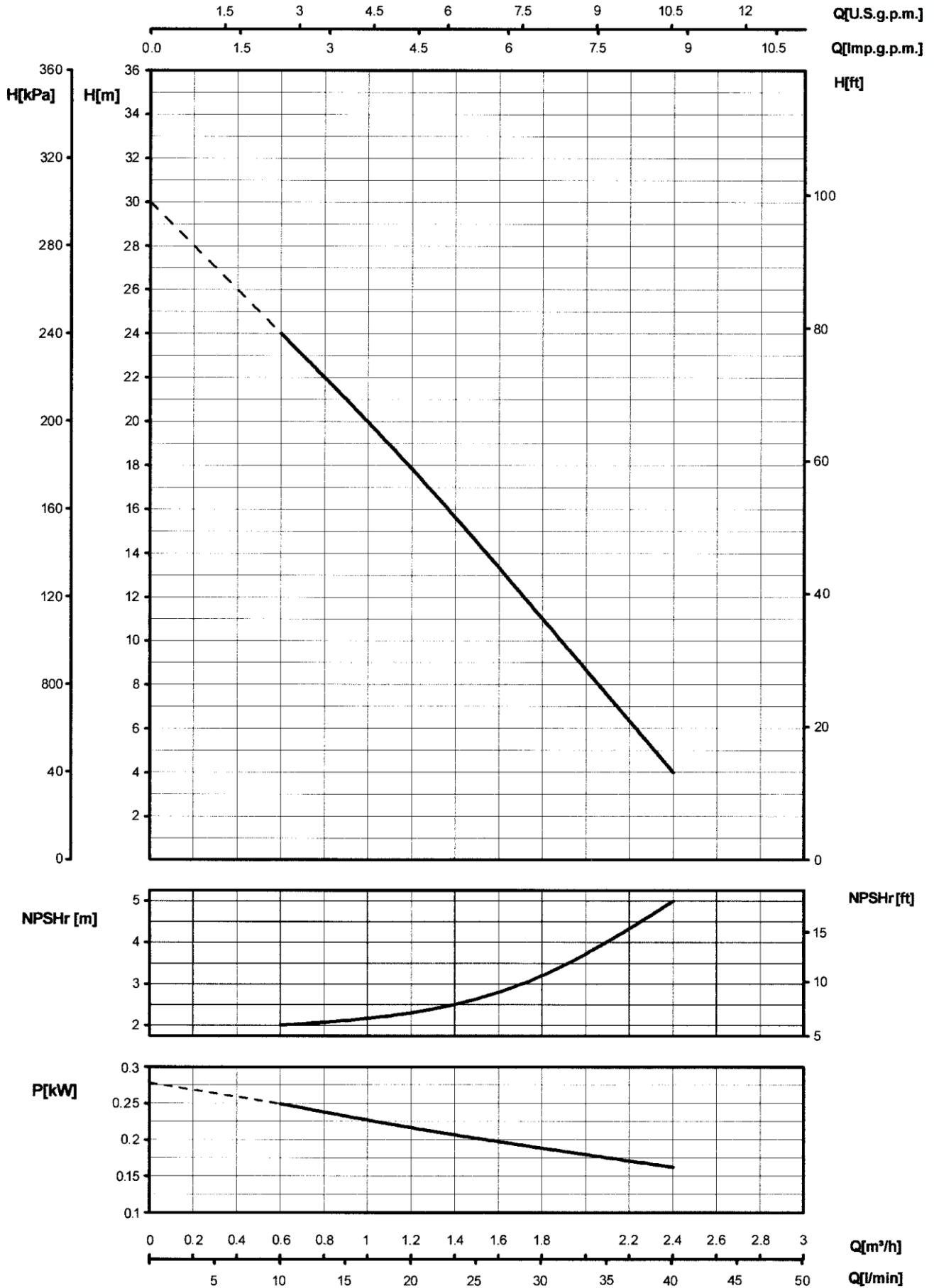

KF1

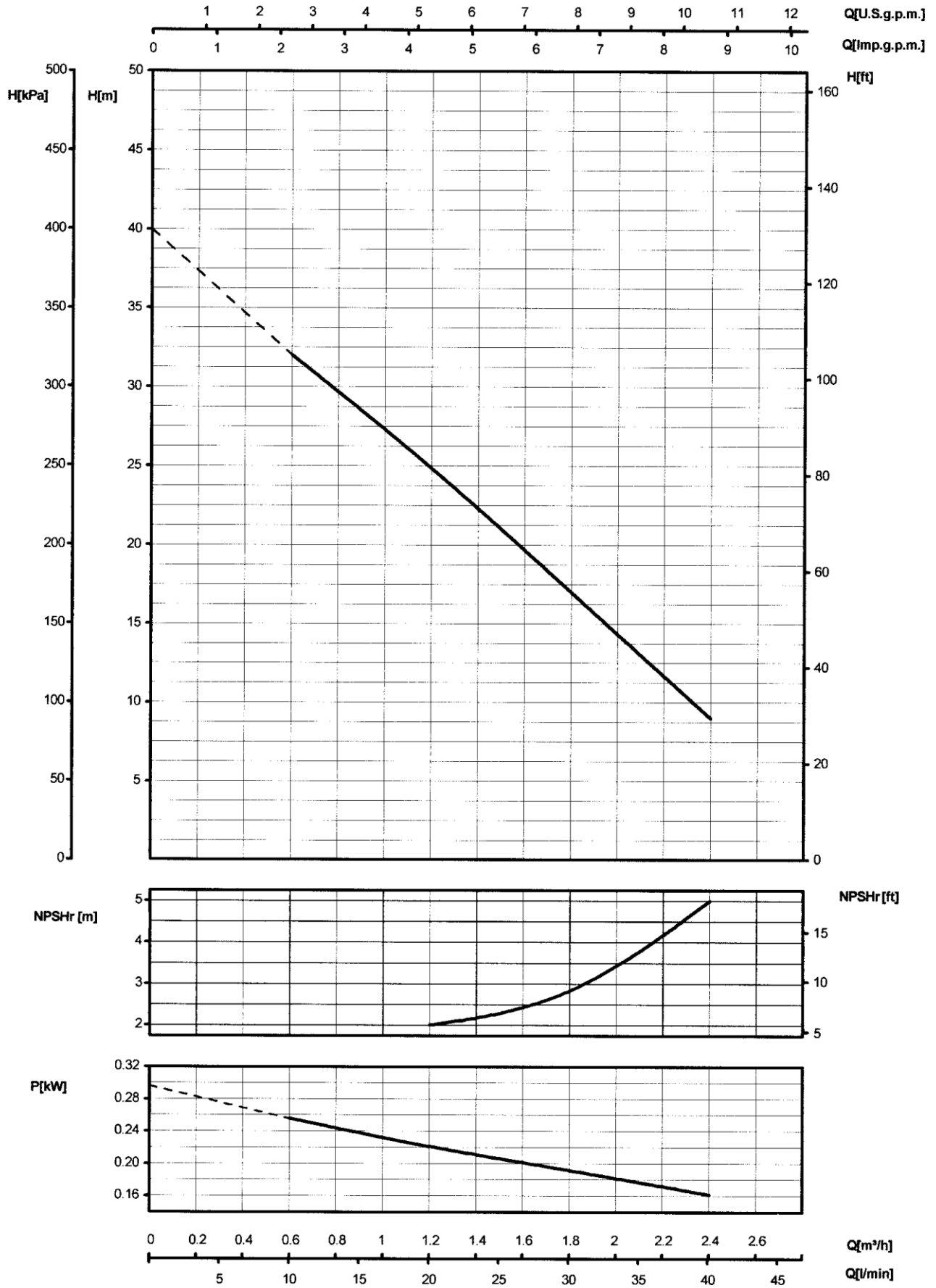

KF2

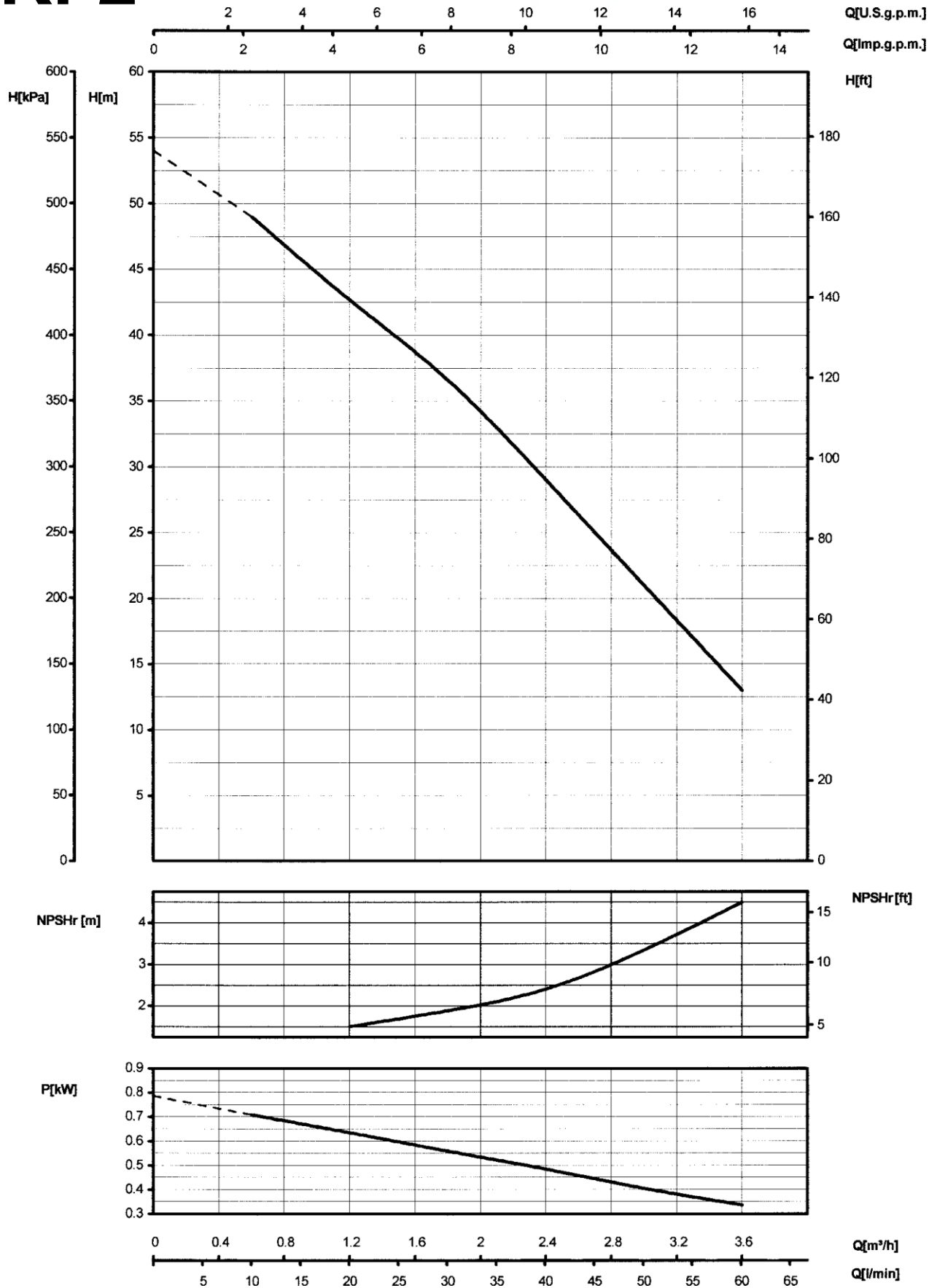

KF3

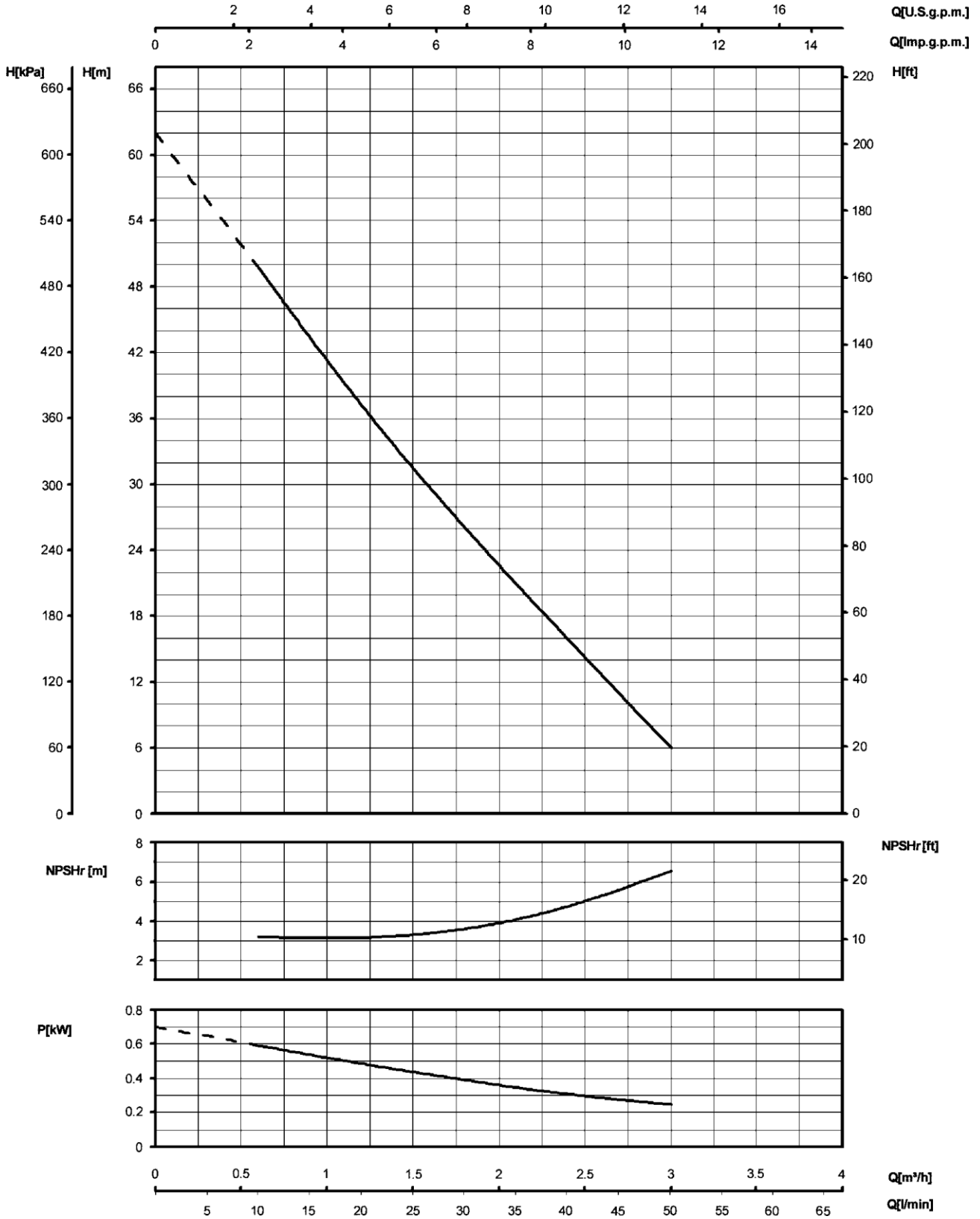

KF4

